

FIG. & INDEX NO.	PART NO.	FSCM	DESCRIPTION 1 2 3 4 5 6 7	UNITS PER ASSY	USABLE ON CODE	SMR CODE
2-1	H-6610	96906	FINISHED PANEL SCREW	12		PAOZZ
	H34-0022-001	14304	CLIP NUT	12		XB
2	10085-0062	14304	BRACKET	2		XB
	10085-0061	14304	SHIM	2		XB
3	10085-0000	14304	100 WATT TRANSCEIVER	1		PEODD
4	10197-2098	14304	RACK, MODIFIED	1		XB
5	10085-0200	14304	POWER SUPPLY	1		PEODD
6	10086-0000	14304	500 WATT LINEAR PWR AMP	1		PEODD
7	MS25281R-8	96906	CLAMP	2		PAOZZ
	MS51958-63	96906	SCREW, MACHINE (AP)	2		PAOZZ
	MS3560-304	96906	NUT (AP)	4		PAOZZ
	10197-2386	14304	LANYARD	2		XB
8	10197-2389	14304	STRUT BRACKET	2		XB
	MS16228-8C	96906	NUT	4		PAOZZ
9	4521-50-100-2N	86928	CLAMP	2		XB
	MS20426A4-3	96906	RIVET	4		PAOZZ
10	10086-0062	14304	BRACKET	2		XB
	10086-0061	14304	SHIM	4		XB
11	10197-2388	14304	STRUT	2		XB
12	10197-2387	14304	SPACER	4		XB
13	10085-0362	14304	BRACKET	2		XB
	10085-0361	14304	SHIM	4		XB

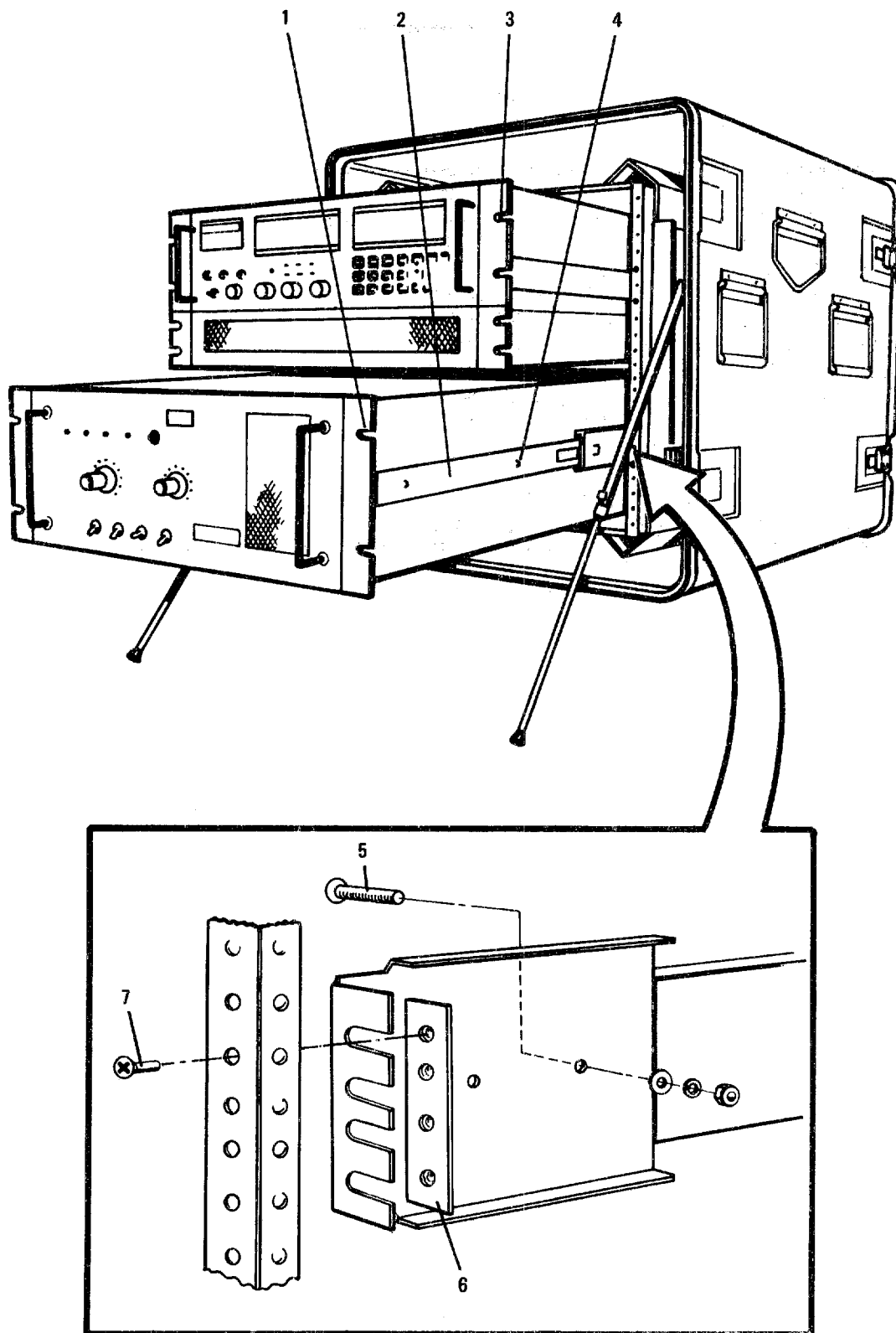
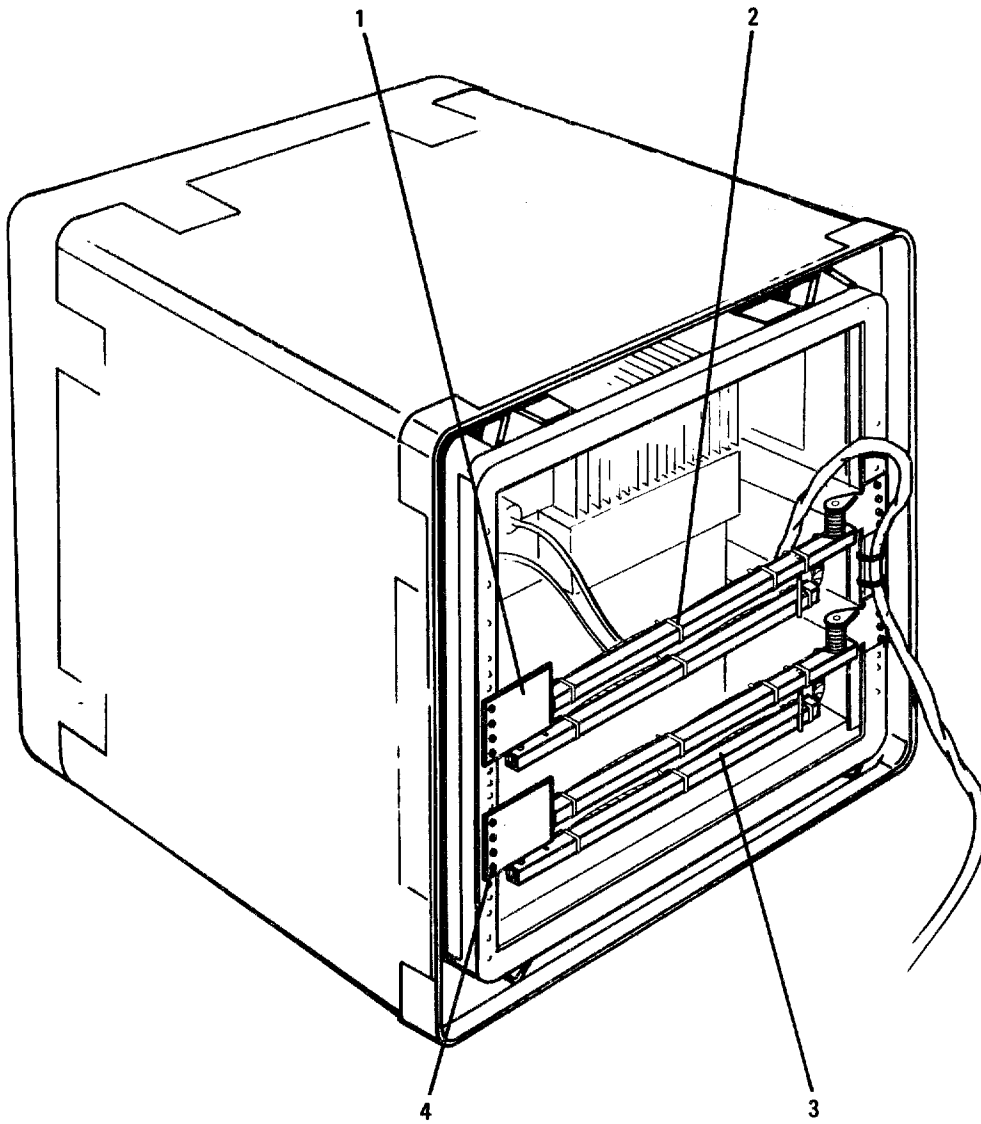

Figure 7-3. Unit 1 Assy, Front Side View

121-012

FIG. & INDEX NO.	PART NO.	FSCM	DESCRIPTION							UNITS PER ASSY	USABLE ON CODE	SMR CODE
			1	2	3	4	5	6	7			
3- 1	MS51957-44	96906	SCREW, MACHINE							8		PAOZZ
	MS15795-807	96906	WASHER, FLAT							8		PAOZZ
	MS35338-137	96906	WASHER, LOCK							8		PAOZZ
2	10085-0208	14304	SLIDE KIT							2		XB
3	MS51957-29	96906	SCREW, MACHINE							8		PAOZZ
	MS15795-805	96906	WASHER, FLAT							8		PAOZZ
	MS35338-136	96906	WASHER, LOCK							8		PAOZZ
4	MS24693-C48	96906	SCREW, MACHINE							16		PAOZZ
5	MS24693-C50	96906	SCREW, MACHINE							16		PAOZZ
	MS15795-807	96906	WASHER, FLAT							16		PAOZZ
	MS35338-137	96906	WASHER, LOCK							16		PAOZZ
	MS35649-284	96906	NUT							16		PAOZZ
6	Z13-0016-001	14304	NUT BAR							4		XB
7	MS24693-C272	96906	SCREW, MACHINE							12		PAOZZ



121-013

Figure 7-4. Unit 1 Assy, Rear View

FIG. & INDEX NO.	PART NO.	FSCM	DESCRIPTION 1 2 3 4 5 6 7	UNITS PER ASSY	USABLE ON CODE	SMR CODE
4- 1	10197-2014	14304	STOP, CABLE RETRACTOR	2		XB
2	MS3367-1-9	96906	CABLE TIE	AS RQ		PAOZZ
3	CRS-25	05236	CABLE RETRACTOR	2		XB
4	MS51958-64	96906	SCREW, MACHINE	16		PAOZZ
	MS15795-808	96906	WASHER, FLAT	16		PAOZZ
	MS35338-138	96906	WASHER, LOCK	16		PAOZZ
	Z13-0016-001	14304	NUT BAR	4		XB

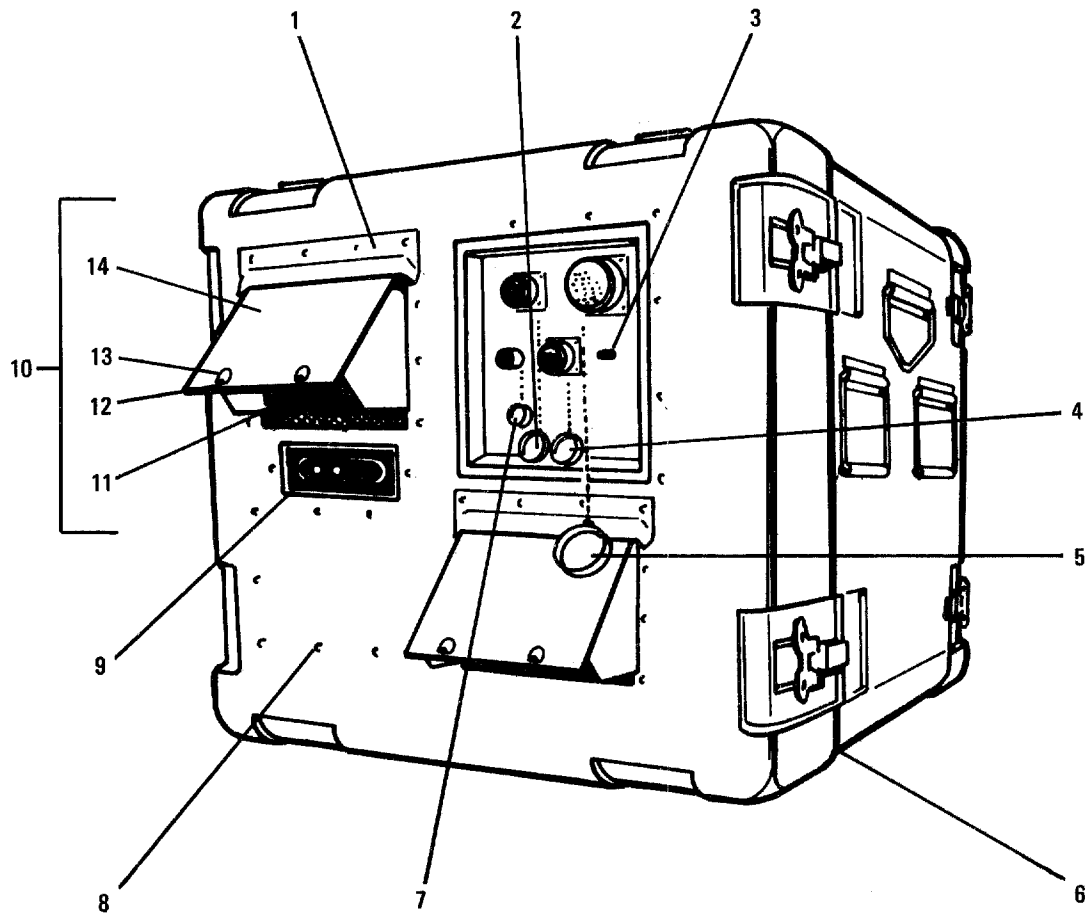

121-014

Figure 7-5. Unit 1 Assy, Rear End Bell, Outside

FIG. & INDEX NO.	PART NO.	FSCM	DESCRIPTION 1 2 3 4 5 6 7	UNITS PER ASSY	USABLE ON CODE	SMR CODE
5- 1	10197-2415	14304	SPLASH GUARD	2		XB
	MS35338-138	96906	WASHER, LOCK	16		PAOZZ
2	MS25043-20D	96906	DUST CAP	1		PAOZZ
3	MS15795-810	96906	WASHER, FLAT	2		PAOZZ
	MS35338-139	96906	WASHER, LOCK	2		PAOZZ
4	MS35425-70	96906	WING NUT	1		PAOZZ
	MS25043-20D	96906	DUST CAP	1		PAOZZ
5	MS25043-24D	96906	DUST CAP	1		PAOZZ
6	10197-2414	14304	GASKET	1		PAOZZ
7	M39012/25-0012	96906	DUST CAP	1		PAOZZ
8	MS51958-64	96906	SCREW, MACHINE	34		PAOZZ
	MS15795-842	96906	WASHER, FLAT	34		PAOZZ
9	MS35338-138	96906	WASHER, LOCK	34		PAOZZ
	MS51958-66	96906	SCREW, MACHINE	4		PAOZZ
10	10197-2412	14304	GASKET	1		PAOZZ
	MS15795-842	96906	WASHER, FLAT	4		PAOZZ
11	MS35338-138	96906	WASHER, LOCK	4		PAOZZ
	10197-2490	14304	AIR PORT ASSY	2		XB
12	10197-2413	14304	GASKET	2		PAOZZ
	10197-2492	14304	. LATCH, INTERLOCK	2		XB
13	MS51957-13	96906	. SCREW, MACHINE	4		PAOZZ
	MS15795-803	96906	. WASHER, FLAT	4		PAOZZ
14	MS35338-135	96906	. WASHER, LOCK	4		PAOZZ
	H15-0018-005	14304	. STUD	4		XB
15	10197-2411	14304	. GASKET	4		PAOZZ
	H15-0018-116	14304	. SNAP RING	4		XB
16	10197-2499	14304	. COVER, AIR PORT	2		XB

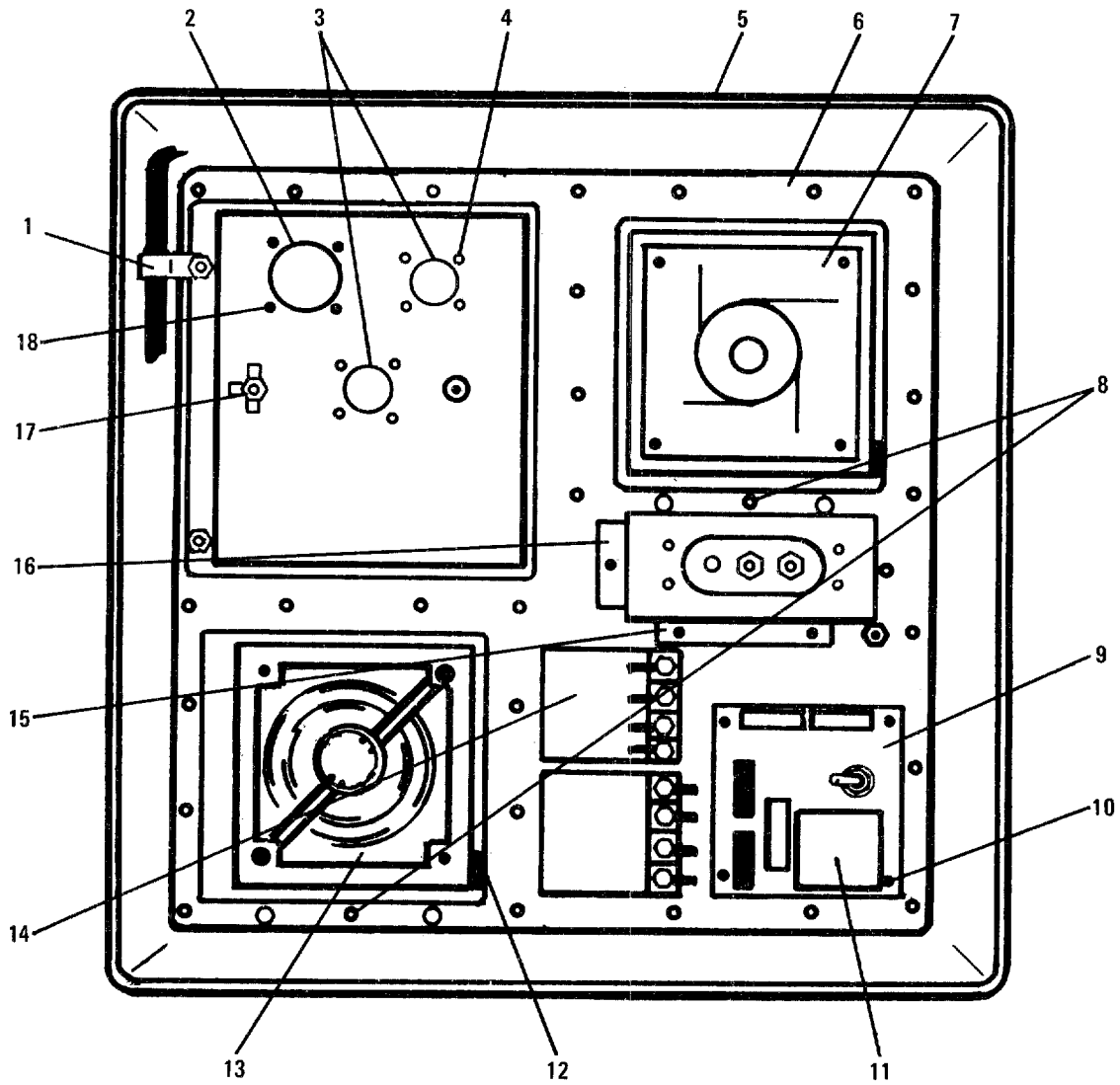

121-015

Figure 7-6. Unit 1 Assy, Rear end Bell, Inside

FIG. & INDEX NO.	PART NO.	FSCM	DESCRIPTION							UNITS PER ASSY	USABLE ON CODE	SMR CODE
			1	2	3	4	5	6	7			
6-	10197-2400	14304	REAR END BELL ASSY							1		XB
1	MS51957-44	96906	. SCREW, MACHINE							4		PAOZZ
	MS15795-807	96906	. WASHER, FLAT							4		PAOZZ
	MS35338-137	96906	. WASHER, LOCK							4		PAOZZ
	MS25281-R14	96906	. CABLE CLAMP							3		PAOZZ
2	10-40450-24	77820	. GASKET							1		PAOZZ
3	10-40450-20	77820	. GASKET							2		PAOZZ
4	MS35649-244	96906	. NUT							8		PAOZZ
	MS15795-804	96906	. WASHER, FLAT							8		PAOZZ
	MS35338-135	96906	. WASHER, LOCK							8		PAOZZ
5	10197-2409	96906	. END BELL (W/O PLATE)							1		XB
6	10197-2419	14304	. BASE PLATE							1		XB
7	MD24B2	82877	. FAN							1		PAOZZ
	10197-2417	14304	. FILTER							1		PAOZZ
	476042	82877	. GUARD, FAN							1		XB
	MS51957-38	96906	. SCREW, MACHINE							4		PAOZZ
	MS15795-806	96906	. WASHER, FLAT							4		PAOZZ
	MS35338-136	96906	. WASHER, LOCK							4		PAOZZ
	MS35649-264	96906	. NUT							4		PAOZZ
	X-1112AK	00287	. STANDOFF							4		
8	MS24693-C271	96906	. SCREW, MACHINE							2		PAOZZ
9	10197-2900	14304	. INTERFACE PWB ASSY							1		PAOZZ
10	8217-A-0632	06540	. STANDOFF							8		PAOZZ
	MS51957-26	96906	. SCREW, MACHINE							8		PAOZZ
	MS15795-806	96906	. WASHER, FLAT							8		PAOZZ
	MS35338-136	96906	. WASHER, LOCK							8		PAOZZ
11	24-BR	08779	. FRAME, TRANSFORMER							1		PAOZZ
12	MS16106-4	96906	. SWITCH, INTERLOCK							2		PAOZZ
	MS51958-13	96906	. SCREW, MACHINE							6		PAOZZ
	MS15795-804	96906	. WASHER, FLAT							10		PAOZZ
	MS35338-135	96906	. WASHER, LOCK							10		PAOZZ
	10197-2418	14304	. TRAVEL STOP, INTERLOCK							2		XB
	MS51957-13	96906	. SCREW, MACHINE							4		PAOZZ
13	10197-2417	14304	. FILTER							1		PAOZZ
	476042	82877	. GUARD, FAN							1		PAOZZ
	MS51957-28	96906	. SCREW, MACHINE							4		PAOZZ
	MS35649-264	96906	. NUT							4		PAOZZ
	MS15795-806	96906	. WASHER, FLAT							4		PAOZZ
	MS35338-136	96906	. WASHER, LOCK							4		PAOZZ
14	PM17DY-24V	77342	. RELAY							2		PAOZZ
	602J	75382	. JUMPER							2		PAOZZ
	MS35649-264	96906	. NUT							6		PAOZZ
	MS15795-806	96906	. WASHER, FLAT							6		PAOZZ
	MS35338-136	96906	. WASHER, LOCK							6		PAOZZ
	35D203	77342	. COVER							2		PAOZZ

FIG. & INDEX NO.	PART NO.	FSCM	DESCRIPTION 1 2 3 4 5 6 7	UNITS PER ASSY	USABLE ON CODE	SMR CODE
15	602-05	75382	. TERMINAL STRIP	1		PAOZZ
	602J	75382	. JUMPER	6		PAOZZ
	MS51957-44	96906	. SCREW, MACHINE	4		PAOZZ
	MS15795-807	96906	. WASHER, FLAT	4		PAOZZ
	MS35338-137	96906	. WASHER, LOCK	4		PAOZZ
16	602-02	75382	. TERMINAL STRIP	1		PAOZZ
	MS51957-44	96906	. SCREW, MACHINE	4		PAOZZ
	MS15795-807	96906	. WASHER, FLAT	4		PAOZZ
	MS35338-137	96906	. WASHER, LOCK	4		PAOZZ
17	MS35650-304	96906	. NUT	2		PAOZZ
	MS77068-4	96906	. GROUND LUG	5		PAOZZ
18	MS35649-264	96906	. NUT	4		PAOZZ
	MS15795-805	96906	. WASHER, FLAT	4		PAOZZ
	MS35338-136	96906	. WASHER, LOCK	4		PAOZZ
	MS77068-2	96906	. GROUND LUG	1		PAOZZ

COMPONENT	INDEX NO.
C1	1
CR1-CR8	2
J1	3
J2	4
K1,K2	5
S1	6
T1	7

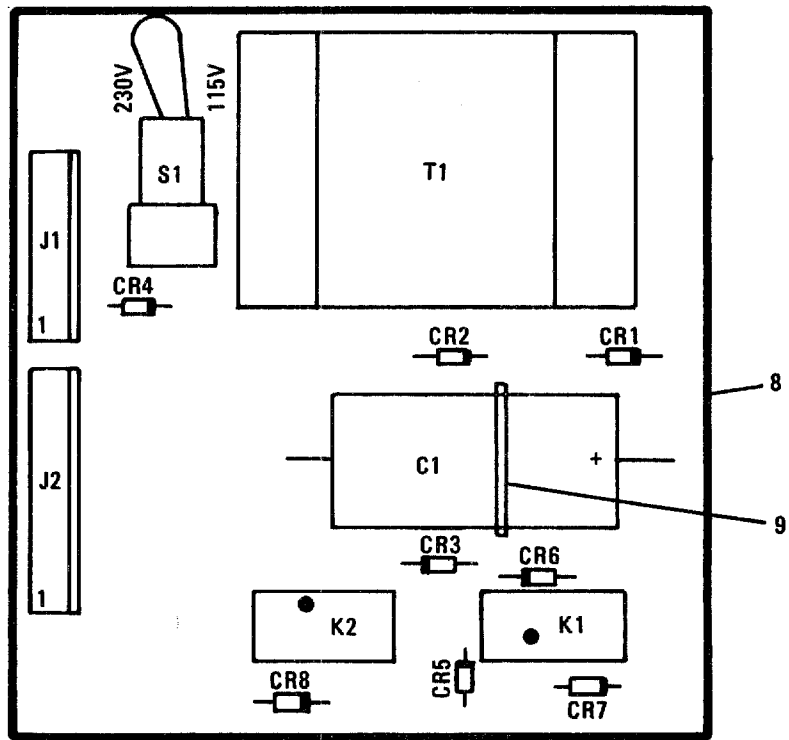

121-016

Figure 7-7. Interface PWB Assy

FIG. & INDEX NO.	PART NO.	FSCM	DESCRIPTION 1 2 3 4 5 6 7	UNITS PER ASSY	USABLE	
					ON CODE	SMR CODE
7 -	10197-2900	14304	INTERFACE PWB ASSY	1	PADZZ	PAODD
1	3050GJ551U063PD	99392	. CAPACITOR	1	PADZZN	PAZZ
2	JAN1N3611	96906	. DIODE	8	PADZZN	PAZZ
3	640445-7	00779	. CONNECTOR	1	PADZZN	PAZZ
4	640445-9	00779	. CONNECTOR	1	PADZZN	PAZZ
5	M39016/6-109L	96906	. RELAY	2	PADZZN	PAZZ
6	MTM-206N-RA	95146	. SWITCH	1	PADZZN	PAZZ
7	DPC-34-700	08779	. TRANSFORMER	1	PADZZN	PAZZ
8	10197-2909	14304	. CIRCUIT BOARD (W/O COMP)	1		XB
9	MS3367-1-9	96906	. CABLE TIE	2		PAOZZ

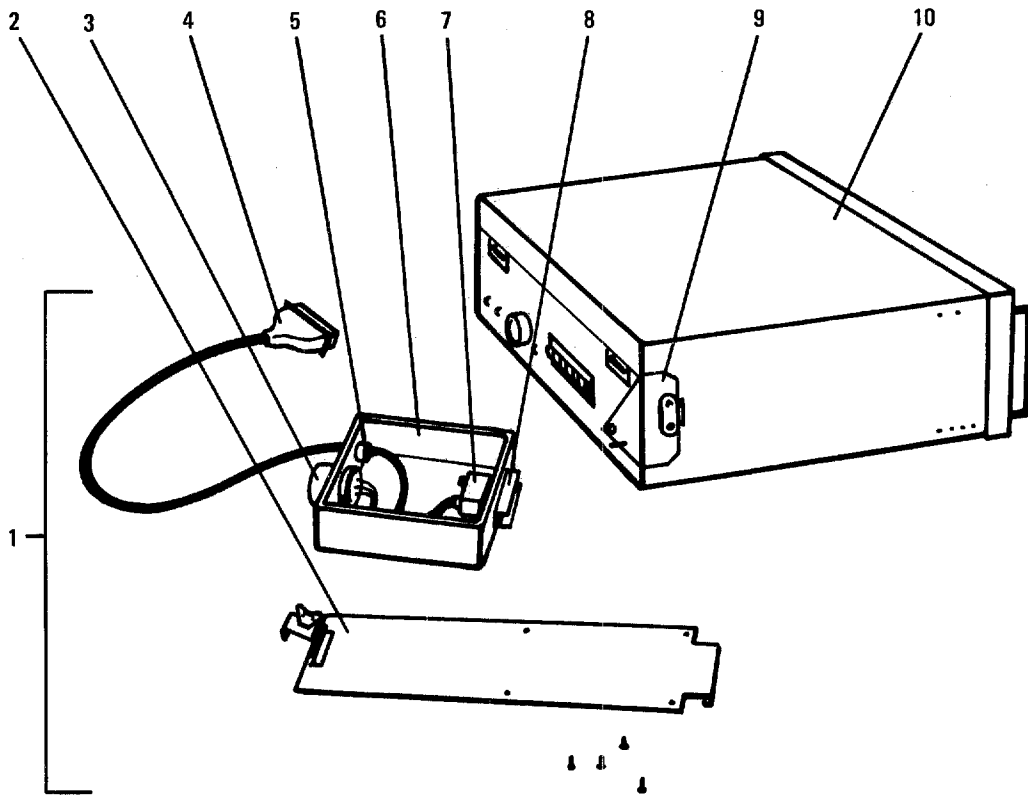

121-017

Figure 7-8. Remote Power Switch Assy and Remote Control Unit

FIG. & INDEX NO.	PART NO.	FSCM	DESCRIPTION 1 2 3 4 5 6 7	UNITS PER ASSY	USABLE ON CODE	SMR CODE
8 - 1	10197-2500	14304	REMOTE POWER SWITCH ASSY	1		PADZZ
2	10197-2508	14304	. MOUNTING BRACKET	1		XB
	MS24693-C26	96906	. SCREW, MACHINE	4		PAOZZ
3	MS3102R24-7S	96906	. CONNECTOR	1		PAOZZ
	MS51957-30	14304	. SCREW, MACHINE	4		PAOZZ
	MS15795-806	96906	. WASHER, FLAT	4		PAOZZ
	MS35338-136	96906	. WASHER, LOCK	4		PAOZZ
	MS35649-264	96906	. NUT	4		PAOZZ
4	DB-25S	02660	. CONNECTOR	1		PADZZ
	745508-5	00779	. FERRULE	1		PAZZ
	745173-4	00779	. HOOD	1		PAZZ
5	1207	51249	. STRAIN RELIEF	1		PAOZZ
6	10197-2509	14304	. BUD BOX	1		XB
7	MS35058-23	96906	. SWITCH	1		PADZZ
8	10197-2506	14304	. SWITCH GUARD	1		XB
9	10197-2507	14304	. STRIKE BRACKET	1		XB
	MS15795-842	96906	. WASHER, FLAT	2		PAOZZ
	MS35338-138	96906	. WASHER, LOCK	2		PAOZZ
	MS35650-304	96906	. NUT	2		PAOZZ
10	10088-0000	14304	REMOTE CONTROL UNIT	1		PEODD

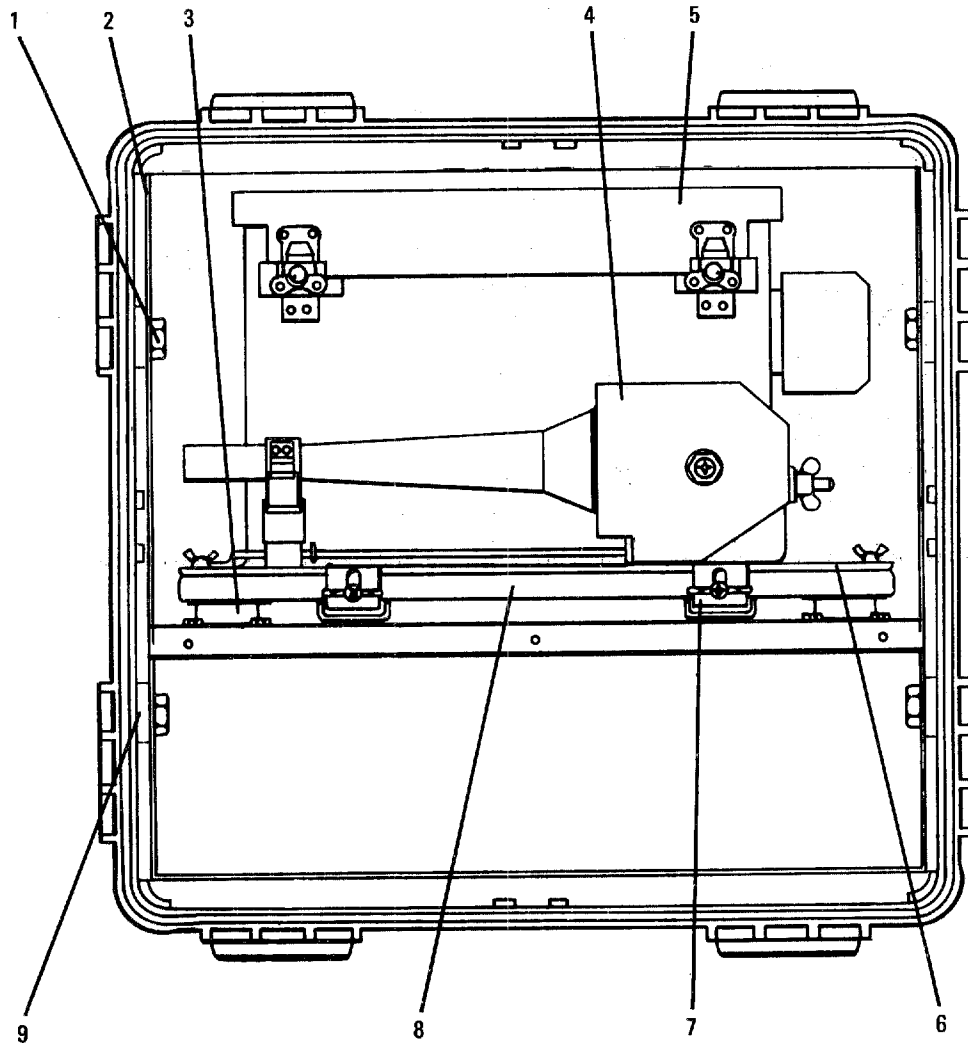

121-018

Figure 7-9. Unit 2 Assy, Front View

FIG. & INDEX NO.	PART NO.	FSCM	DESCRIPTION 1 2 3 4 5 6 7	UNITS PER ASSY	USABLE ON CODE	SMR CODE
9- 1	10197-4017	14304	NUT	8		XB
2	10197-4019	14304	CHASSIS	1		XB
3	NC-1010-T4	81860	SHOCK MOUNT	4		XB
	MS15795-842	96906	WASHER, FLAT	16		PAOZZ
	MS35338-138	96906	WASHER, LOCK	16		PAOZZ
	MS35650-304	96906	NUT	16		PAOZZ
4	10197-4100	14304	ANTENNA GROUP ASSY	1		XA
5	10094-0000	14304	. ANTENNA COUPLER	1		PEODD
	MS15795-812	96906	. WASHER, FLAT	4		PAOZZ
	MS35338-140	96906	. WASHER, LOCK	4		PAOZZ
	MS35649-2314	96906	. NUT	4		PAOZZ
6	10197-4110	96906	. CPLR/ANTENNA PLATE ASSY	1		XB
7	10197-4015	14304	CLAMP	2		XB
	10089-0012	14304	STUD	2		XB
	10089-0017	14304	WING NUT	2		XB
	MS51958-16B	96906	SCREW, MACHINE	2		PAOZZ
8	10197-4016	14304	TRAY	1		XB
	MS51957-83	96906	. SCREW, MACHINE	4		PAOZZ
	MS15795-810	96906	. WASHER, FLAT	4		PAOZZ
	MS35338-139	96906	. WASHER, LOCK	4		PAOZZ
9	10197-4018	14304	. SPACER	8		XB

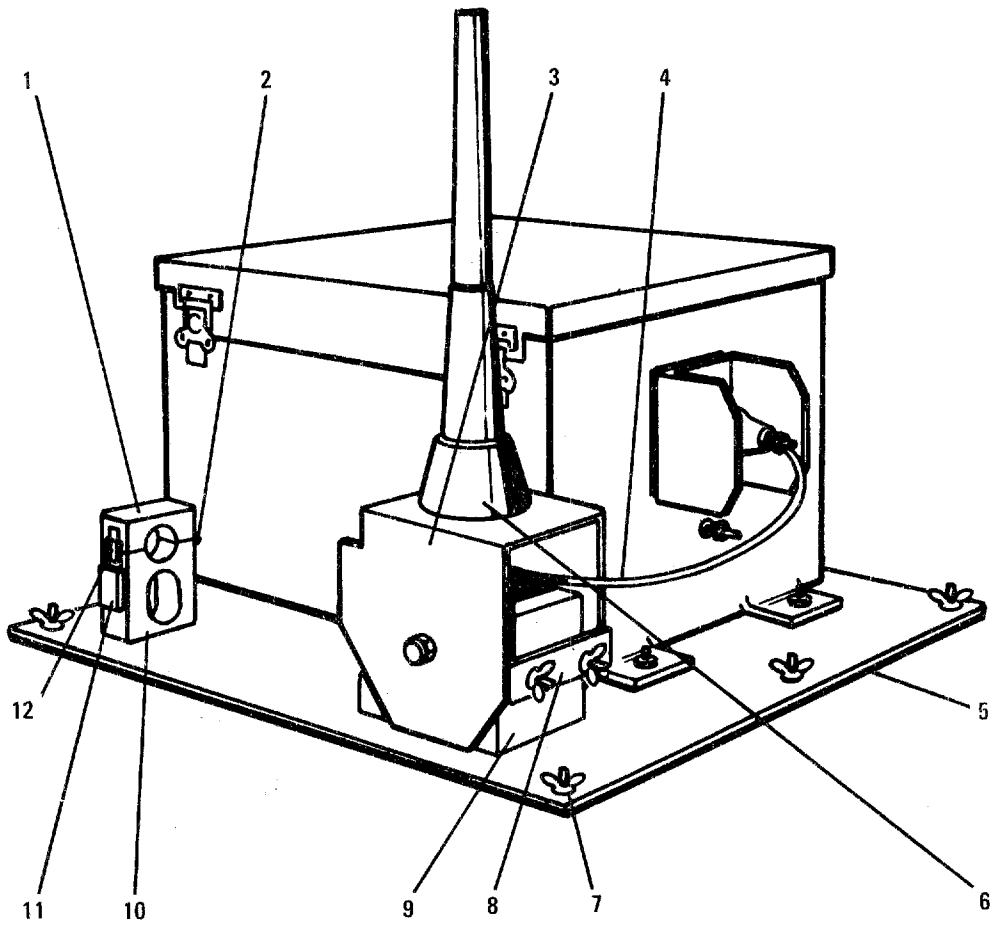

121-019

Figure 7-10. Antenna Group Assy

FIG. & INDEX NO.	PART NO.	FSCM	DESCRIPTION 1 2 3 4 5 6 7	UNITS PER ASSY	USABLE ON CODE	SMR CODE
10 -	10197-4100	14304	ANTENNA GROUP ASSY	1		XA
1	10197-4107	14304	. UPPER SUPPORT BLOCK	1		XB
	PO5-0003-007	14304	. RUBBER TAPE	AS RQ		XB
	MS51957-26	96906	. SCREW, MACHINE	4		PAOZZ
	MS35338-136	96906	. WASHER, LOCK	4		PAOZZ
2	10197-4106	14304	. HINGE	1		XB
	MS51957-13	96906	. SCREW, MACHINE	4		PAOZZ
	MS15795-804	96906	. WASHER, FLAT	4		PAOZZ
	MS35338-135	96906	. WASHER, LOCK	4		PAOZZ
3	10197-4118	14304	. UPPER ANTENNA MTG BRACKET	1		XB
	MS35307-360		. BOLT, HEX, 3/8" x 1"	2		PAOZZ
	MS15795-815		. WASHER, FLAT	4		PAOZZ
	MS35338-141		. WASHER, LOCK	2		PAOZZ
	755017B0763		. BUSHING	2		XB
4	10101-4575	14304	. H.V. WIRE	24 IN		XB
	61214	79061	. LUG	2		XB
5	10197-4109	14304	. PLATE	1		XB
6	E-0150	14304	. ANTENNA BASE	1		XB
7	MS35425-70	96906	. NUT, WING	5		PAOZZ
	MS15795-810	96906	. WASHER, FLAT	10		PAOZZ
	MS35338-139	96906	. WASHER, LOCK	5		PAOZZ
8	10197-4116	14304	. NUT BAR	1		XB
	MS24693-C28	96906	. SCREW, MACHINE	2		PAOZZ
	10197-4117	14304	. BAR, LOCKING	1		XB
	10089-0012	14304	. STUD	2		XB
	10089-0017	14304	. NUT, WING	2		XB
	MS51958-61B	96906	. SCREW, MACHINE	2		PAOZZ
9	10197-4119	14304	. BRACKET, ANTENNA MTG BASE	1		XB
	MS24693-C140	96906	. SCREW, MACHINE	4		PAOZZ
10	10197-4108	14304	. BLOCK, LOWER SUPPORT	1		XB
	P05-0003-007	14304	. RUBBER TAPE	AS RQ		XB
	MS24693-C272	14304	. SCREW, MACHINE	2		XB
11	SC-B-83314-SS302	98003	. STRIKE	1		XB
	MS51957-43	96906	. SCREW, MACHINE	2		PAOZZ
	MS15795-806	96906	. WASHER, FLAT	2		PAOZZ
	MS35338-136	96906	. WASHER, LOCK	2		PAOZZ
12	SC-B-83314-2002-SS302	98003	. PLATE	1		XB
	MS51957-43	96906	. SCREW, MACHINE	2		PAOZZ
	MS15795-806	96906	. WASHER, FLAT	2		PAOZZ
	MS35338-136	96906	. WASHER, LOCK	2		PAOZZ

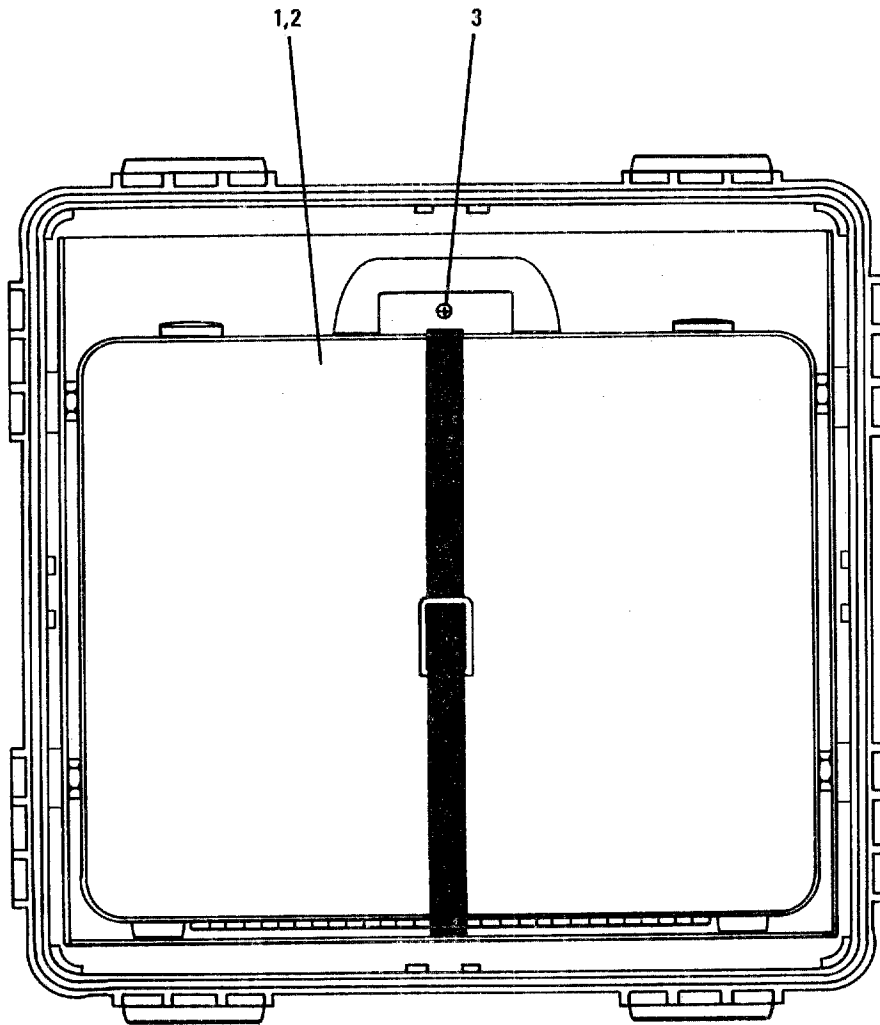

121-020

Figure 7-11. Remote Group Assy

FIG. & INDEX NO.	PART NO.	FSCM	DESCRIPTION 1 2 3 4 5 6 7	UNITS PER ASSY	USABLE ON CODE	SMR CODE
11 - 1	10197-4300	14304	REMOTE GROUP ASSY	1		XA
2	10197-4390	14304	. CASE	1		XB
	10085-0068	14304	. MICROPHONE (Inside CASE)	1		XB
	10197-2500	14304	. REMOTE PWR SWITCH ASSY (Inside CASE--See figure 8)	1		PAODD
	10088-0000	14304	. REMOTE CONTROL UNIT (Inside CASE--See figure 8)	1		PEODD
	10085-0065	14304	. CABLE ASSY, REMOTE POWER (Inside CASE--See figure 13)	1		XB
3	MS51957-77	96906	SCREW, MACHINE	2		PAOZZ
	MS15795-810	96906	WASHER, FLAT	2		PAOZZ
	MS35338-139	96906	WASHER, LOCK	2		PAOZZ
	10197-4020	14304	STRAP, CANVAS	1		XB
	10197-4021	14304	STRAP, CANVAS (WITH BUCKLE)	1		XB

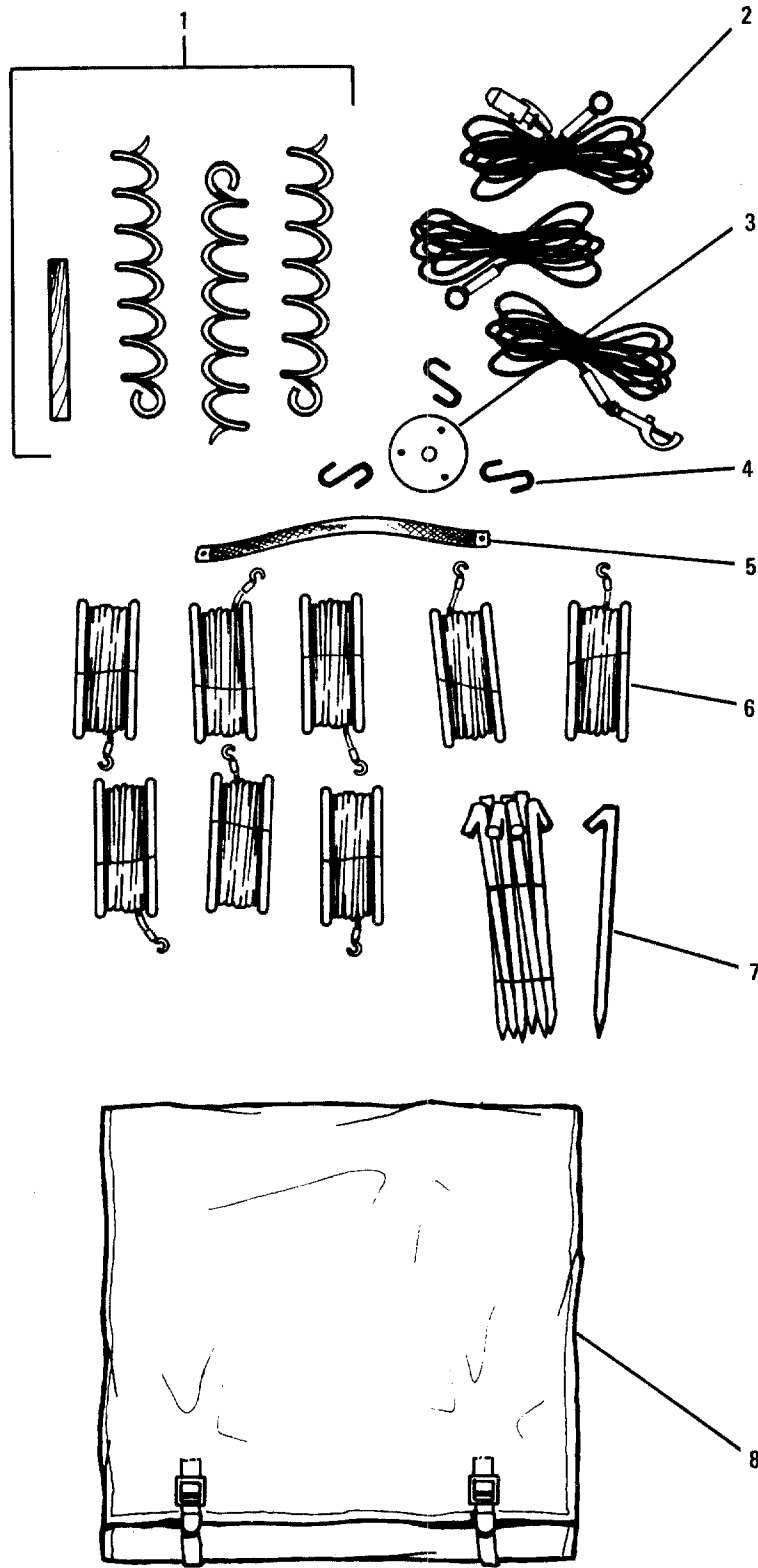

121-021

Figure 7-12. Antenna Installation Kit

FIG. & INDEX NO.	PART NO.	FSCM	DESCRIPTION 1 2 3 4 5 6 7	UNITS PER ASSY	USABLE ON CODE	SMR CODE
12 -	10197-4200	14304	ANTENNA STABILIZER KIT	1		XB
1	10197-4208	14304	. GUY KIT	1		XB
2	6906-0102	14304	. GUY ASSY	3		XB
3	2066-0002	14304	. GUY RING	1		XB
4	6906-4001	14304	. S-HOOK	3		XB
5	2066-0005	14304	. GROUND STRAP	1		XB
6	10197-4211	14304	. RADIAL WIRE ASSY	8		XB
	10197-4218	14304	. . BAR	2		XB
	8174-A-0632-16	06540	. . SPACER	2		XB
	MS51957-31	96906	. . SCREW, MACHINE	4		PAOZZ
	MS15795-805	96906	. . WASHER, FLAT	4		PAOZZ
	8899	70983	. . H.V. WIRE	60 FT		XB
	321633	00779	. . LUG HOOK	1		XB
	LC-136	92194	. . LACE CORD	2 FT		XB
7	10197-4212	14304	. TENT STAKE	8		XB
8	10197-4209	14304	. BAG	1		XB

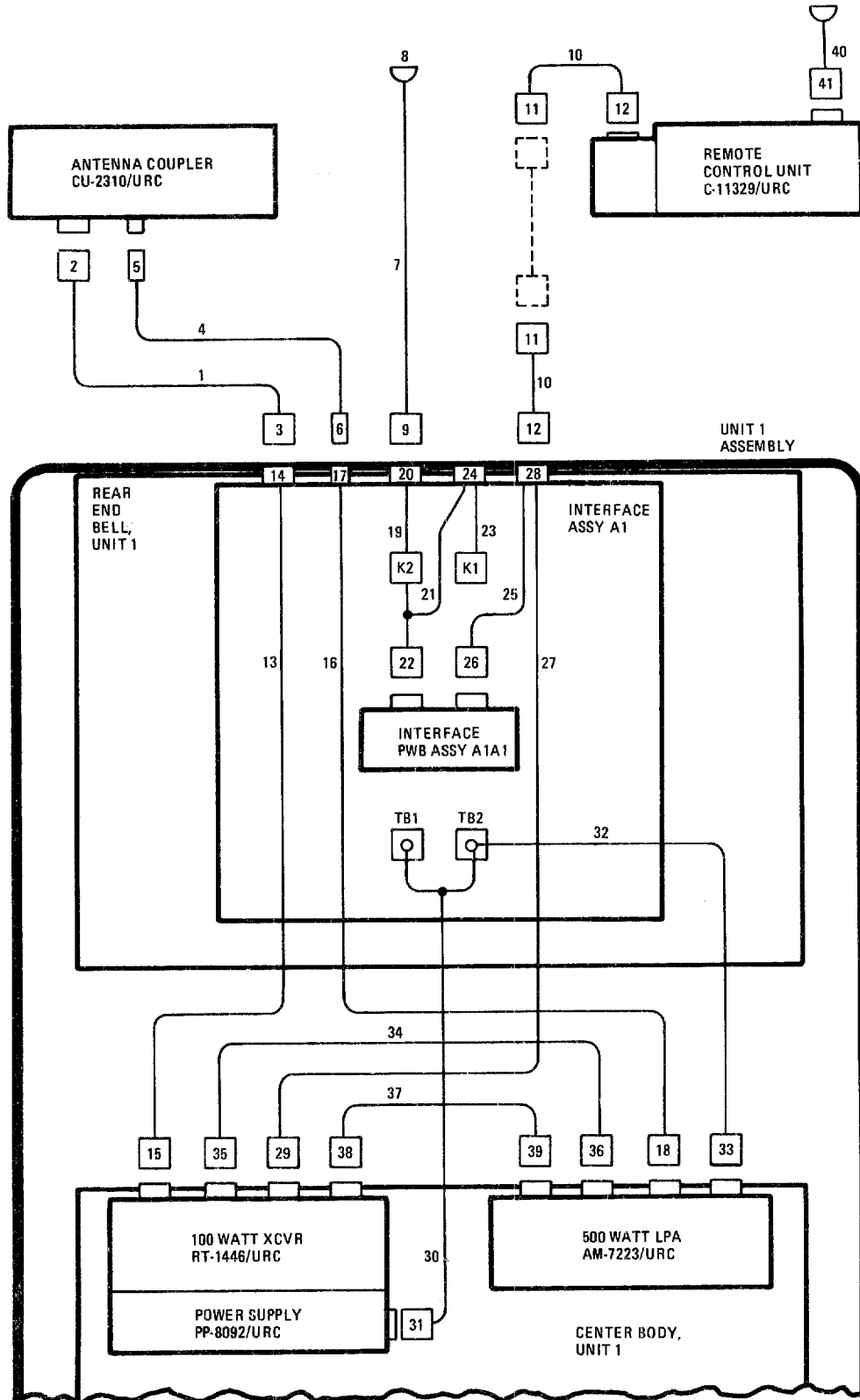

121-022

Figure 7-13. Cables and Connectors

FIG. & INDEX NO.	PART NO.	FSCM	DESCRIPTION 1 2 3 4 5 6 7	UNITS PER ASSY	USABLE ON CODE	SMR CODE
13 - 1	10197-2115	14304	CABLE ASSY, ANT CPLR CONTRL	1		MDD
2	MS3106F20-27S	96906	. CONNECTOR, 14 SOCKET	1		PADZZ
3	MS3106F20-27P	96906	. CONNECTOR, 14 PIN	1		PADZZ
	MS3420-12A	96906	. SLEEVE	2		PAOZZ
4	10197-2114	14304	CABLE ASSY, ANT CPLR RF	1		MDD
5, 6	M39012/01-0005	96906	. CONNECTOR, COAX	2		PAOZZ
7	10197-2116	14304	CABLE ASSY, AC POWER	1		XB
8	5366-C	83315	. PLUG, AC	1		PAOZZ
9	MS3106F20-15S	96906	. CONNECTOR, 7 SOCKET	1		PADZZ
	MS3420-12A	96906	. SLEEVE	1		PADZZ
10	10197-2112	14304	CABLE ASSY, REMOTE ADAPTER	2		MDO
11	U-185B/G	91662	. CONNECTOR, HERMAPHRODITIC	1		PADZZ
12	MS3106F24-7P	96906	. CONNECTOR, 20 PIN	1		PADZZ
	MS3420-12A	96906	. SLEEVE	1		PAOZZ
13	10197-2101	14304	CABLE ASSY, ANT CPLR	1		MDD
14	MS3102R20-27S	96906	. CONNECTOR, 27 SOCKET	1		PADZZ
15	MS3106A20-27P	96906	. CONNECTOR, 27 PIN	1		PADZZ
	MS3057-12B	96906	. CABLE CLAMP	1		PAOZZ
	10-36233-243	77820	. CABLE CLAMP SUPPORT	1		PADZZ
	MS3420-12A	96906	. SLEEVE	1		PAOZZ
16	10197-2107	14304	CABLE ASSY, LPA RF	1		MDD
17	755017A4016-02	96906	. CONNECTOR, RF, BULKHEAD	1		PADZZ
18	UG536C/U	96906	. CONNECTOR, RF, PLUG	1		PADZZ
19	10197-2105	14304	CABLE ASSY, AC POWER	1		MDD
20	MS3102R20-15P	96906	. CONNECTOR, 15 PIN	1		PADZZ
21	10197-2110	14304	CABLE ASSY, AC CONTACTOR	1		MDD
22	640428-7	00779	. CONNECTOR, 7 PIN	1		PADZZ
	640550-7	00779	. COVER, CONNECTOR	1		PAOZZ
	09-75-1031	27264	. KEYING PLUG	2		PADZZ
23	10197-2106	14304	CABLE ASSY, DC POWER	1		XB
24	MS3506-1	96906	. PLUG, 3 PIN	1		PAOZZ
25	10197-2111	14304	CABLE ASSY, DC CONTACTOR	1		MDD
26	640428-9	00779	. CONNECTOR, 9 PIN	1		PADZZ
	640550-9	00779	. COVER, CONNECTOR	1		PADZZ
	09-75-1031	27264	. KEYING PLUG	1		PADZZ
27	10197-2102	14304	CABLE ASSY, REMOTE CONTROL	1		MDO
28	MS3102R24-7S	96906	. CONNECTOR, 20 SOCKET	1		PADZZ
29	DB-25S	71468	. CONNECTOR, 25 SOCKET, TYP D	1		PADZZ
	745173-4	00779	. HOOD, D CONNECTOR	1		PADZZ
	745508-5	00779	. FERRULE	1		PADZZ
30	10197-2103	14304	CABLE ASSY, XCVR POWER	1		MDD
31	MS3106A20-8S	96906	. CONNECTOR, 6 SOCKET	1		PADZZ
	MS3057-12A	96906	. CABLE CLAMP	1		PADZZ
	MS3420-10	96906	. SLEEVE, 18 SHELL	1		PADZZ
	MS3420-12	96906	. SLEEVE, ADAPTER	1		PADZZ
	MS3420-8	96906	. SLEEVE	1		PADZZ

FIG. & INDEX NO.	PART NO.	FSCM	DESCRIPTION 1 2 3 4 5 6 7	UNITS PER ASSY	USABLE ON CODE	SMR CODE
32	10197-2104	14304	CABLE ASSY, LPA POWER	1		MDD
33	MS3106A28-20S	96906	. CONNECTOR, 14 SOCKET	1		PADZZ
	MS3057-16A	96906	. CABLE CLAMP	1		PADZZ
	MS3420-10	96906	. SLEEVE, 18 SHELL	1		PADZZ
	MS3420-12	96906	. SLEEVE, ADAPTER	1		PADZZ
	MS3420-16	96906	. SLEEVE, ADAPTER	1		PADZZ
	MS3420-8	96906	. SLEEVE	1		PADZZ
34	10197-2109	14304	CABLE ASSY, LPA CONTROL	1		MDD
35	DP-25P	71468	. CONNECTOR, 25 PIN	1		PADZZ
36	DP-25S	71468	. CONNECTOR, 25 SOCKET	1		PADZZ
	745173-2	00779	. HOOD, D CONNECTOR	2		PADZZ
	745508-8	00779	. FERRULE	2		PADZZ
37	10197-2108	14304	CABLE ASSY, LPA-XCVR, RF	1		MDD
38,39	UG536C/U	96906	. CONNECTOR, RF	2		PADZZ
40	10085-0065	14304	CABLE ASSY, REMOTE POWER	1		MDD
41	MS3057-12A	96906	. CLAMP, CABLE	1		PADZZ
	MS3106A20-8S	96906	. CONNECTOR, 6 PIN	1		PADZZ
	MS3420-10	96906	. SLEEVE	1		PADZZ
	MS3420-12	96906	. SLEEVE	1		PADZZ
	MS3420-8	96906	. SLEEVE	1		PADZZ

CHAPTER 8
FOLDOUT DRAWINGS

LIST OF AN/URC-121(V)-1 FOLDOUT DRAWINGS

- FO-1 Family Tree AN/URC-121(V)-1**
- FO-2 System Interconnection Diagram**
- FO-3 Interface Assy Schematic Diagram**

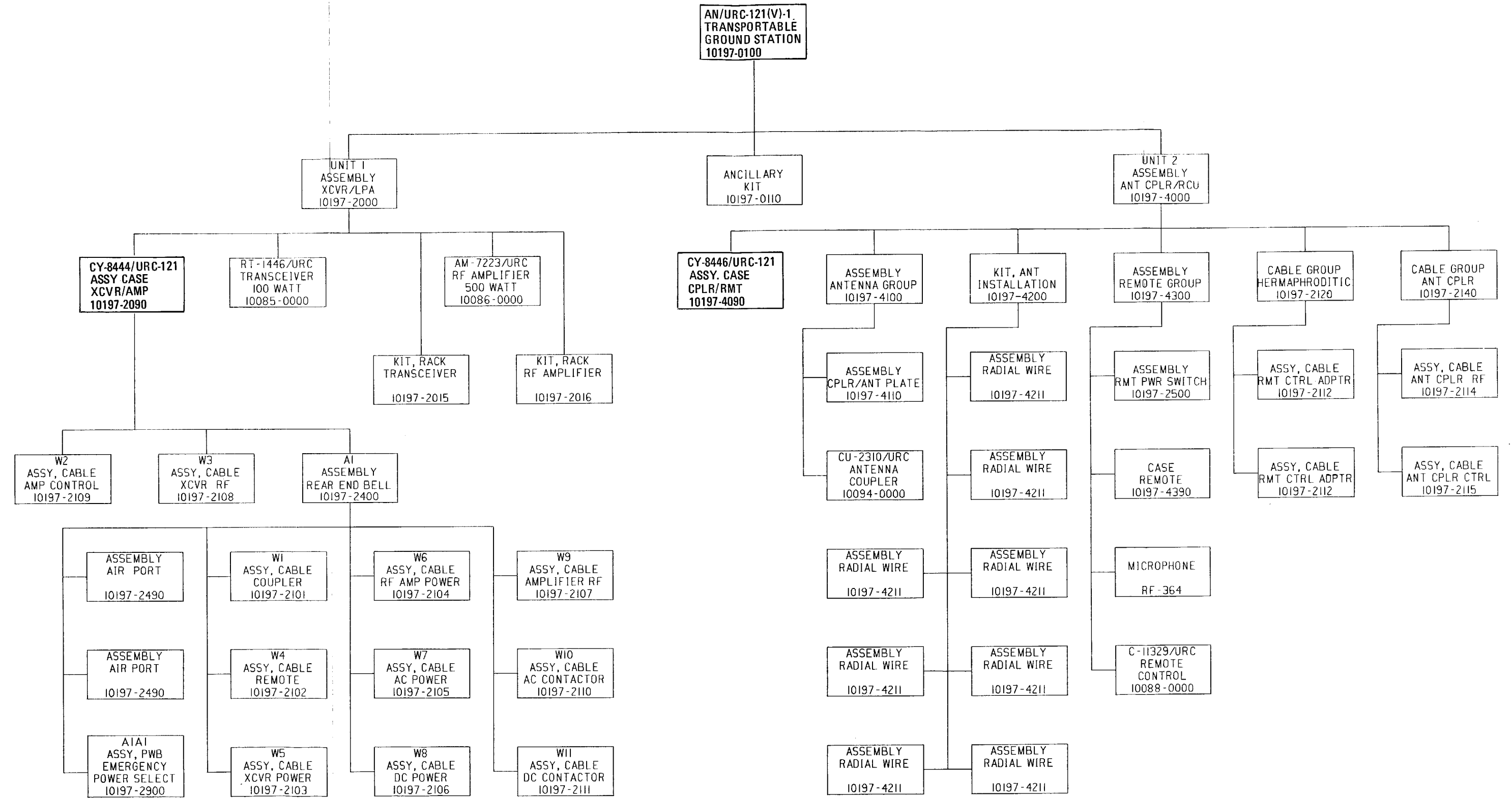
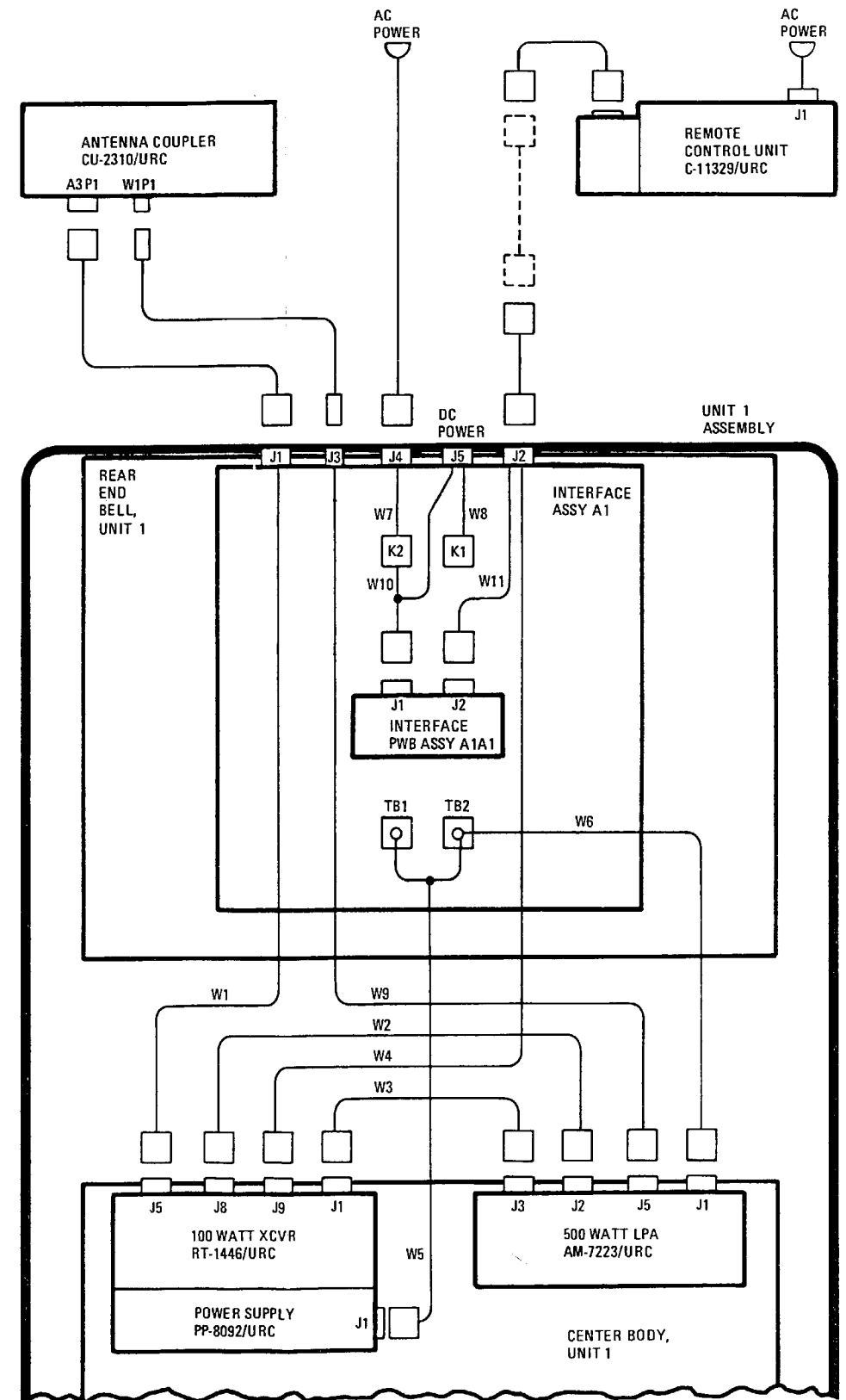

Figure FO-1. Family Tree AN/URC-121(V)-1



121-005

Figure FO-2. System Interconnection Diagram

- NOTE: UNLESS OTHERWISE SPECIFIED:
- PARTIAL REFERENCE DESIGNATIONS ARE SHOWN. FOR A COMPLETE DESIGNATION, PREFIX WITH UNIT NO. AND/OR ASSEMBLY NO. DESIGNATION.
 - ALL RESISTOR VALUES ARE IN OHMS. 1/4W. ±5%.
 - ALL CAPACITOR VALUES ARE IN MICROFARADS.
 - VENDOR PART NO. CALLOUTS ARE FOR REFERENCE ONLY. COMPONENTS ARE SUPPLIED PER PART NO. IN PARTS LIST.
 - PANEL DETAILS ARE INDICATED BY BOLD TYPE IN A BOLD BOX, I.E. **ON/OFF**

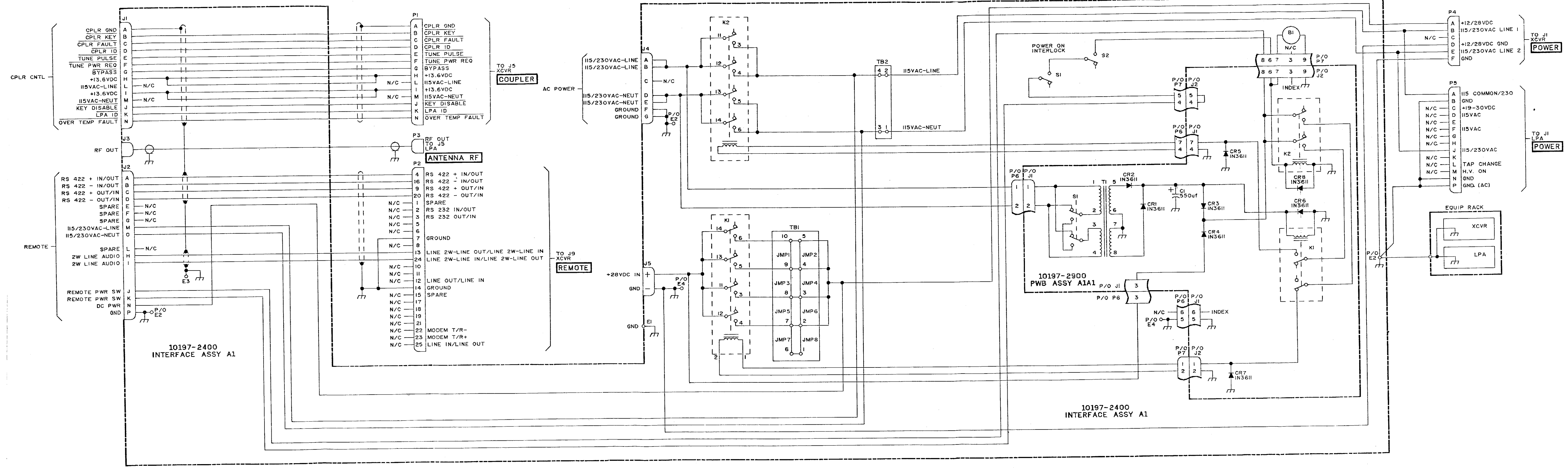
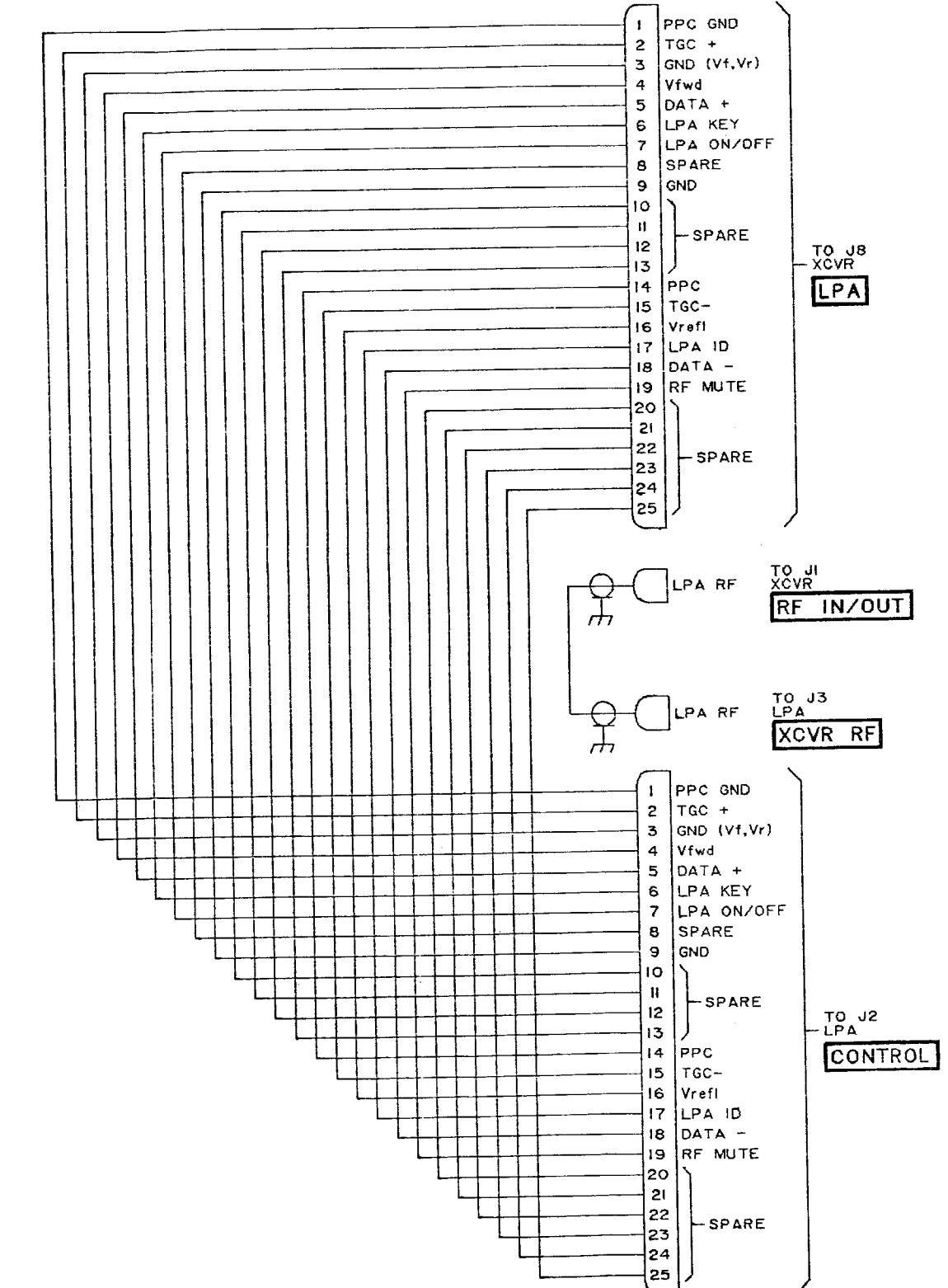

Figure FO-3. Interface Assy Schematic Diagram

